

DESCRIPTION

Encapsulated coil incorporating the magnetic circuit.
 Fixing by means of a central nut.
 Electrical connection according to DIN 43650 B
 (B Industrial connection)

CONSTRUCTION

Class F encapsulation	Fibre-glass Nylon
Class H encapsulation	Fibre-glass Polyarylamide
Magnetic circuit	Zinc-plated steel
Windings	Copper covered with class H insulation
Ambient temperature:	class F -10°C +55°C
	class H -10°C +80°C
	UL coil -10°C +60°C

OPTIONS: Electrical connection through cable
 Special powers and voltages
 Self-extinguish

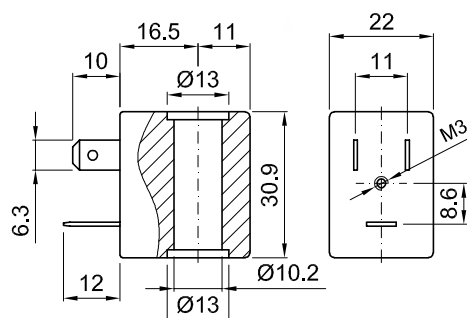

CODE		Alternating Current Voltage	Direct Current Voltage (V)	Power ①		Voltage tolerance		Connector	Service ED
Class F insulation	Class H insulation			Alternating Current (VA)	Direct Current (W)	Alternating current	Direct current		
30A	32A	12V 50/60Hz	-	8	-	+15%	-	10348000	100%
30B	32B	24V 50/60Hz	-						
30C	32C	48V 50/60Hz	-						
30D	32D	110V 50/60Hz	-			-10%			
30E	32E	220/230V 50/60Hz	-						
30F	32F	240V 50/60Hz	-						
30G	32G	380V 50/60Hz	-	3.5		±10%	-		
30E1P	-	220/230V 50/60Hz	-						
300	320	-	12	-	6.5	-	±10%		
301	321	-	24						
302	322	-	48						

Certified versions **US**

NOTE: The performance with UL coil could be different. Please contact the manufacturer for any further information.

-	U35B	24V 60Hz	-	8	-	±10%	-	10348000	100%
-	U35D	120V 60Hz	-						
-	U35F	240V 60Hz	-						
-	U350	-	12	-	6.5	-	±10%		
-	U351	-	24						

Certified versions

-	V32E	220/230	-	8	-	+15% -10%	-	10348000	100%
---	------	---------	---	---	---	--------------	---	----------	------

① Considering nominal voltage and an ambient temperature of 20°C